

# PRODUKTÜBERSICHT PRODUCT OVERVIEW

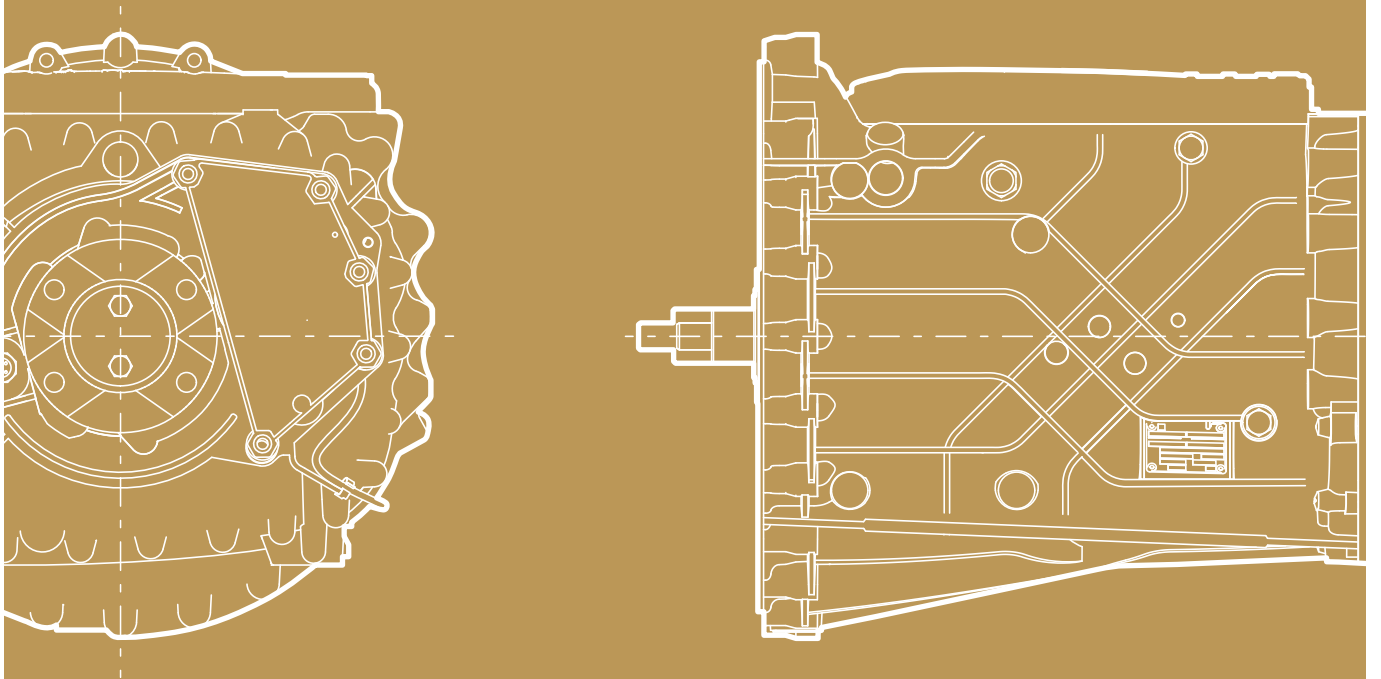

LKW- UND VAN-ANTRIEBSTECHNIK  
TRUCK & VAN DRIVELINE TECHNOLOGY



## INHALT

### AUTOMATISIERTE GETRIEBE / AUTOMATED TRANSMISSIONS

TraXon / TraXon	Seite / Page	4
TC Tronic / TC Tronic	Seite / Page	6
EcoTronic mid / EcoTronic mid	Seite / Page	7
AS Tronic mid / AS Tronic mid	Seite / Page	8
AS Tronic lite / AS Tronic lite	Seite / Page	9

### MANUELLE GETRIEBE / MANUAL TRANSMISSIONS

Ecosplit / Ecosplit	Seite / Page	10
Ecomid / Ecomid	Seite / Page	11
Ecolite für leichte Lkw / Ecolite for light trucks	Seite / Page	12
Ecolite für Van und Pickup / Ecolite for Van and Pickup	Seite / Page	13

### ZUSATZAGGREGATE / AUXILIARY UNITS

Intarder für TraXon / Intarder for TraXon	Seite / Page	14
Intarder für Ecosplit / Intarder for Ecosplit	Seite / Page	15
Intarder für Ecomid / Intarder for Ecomid	Seite / Page	16

### NEBENABTRIEBE / POWER-TAKE-OFFS (PTO)

für Automatisierte Getriebe / for Automated Transmissions	Seite / Page	18
für Manuelle Getriebe / for Manual Transmissions	Seite / Page	20

### ÜBERSICHT / OVERVIEW

Bezeichnung der Getriebe / Transmission Designations	Seite / Page	22
--	--------------	----

# TRAXON

# TRAXON

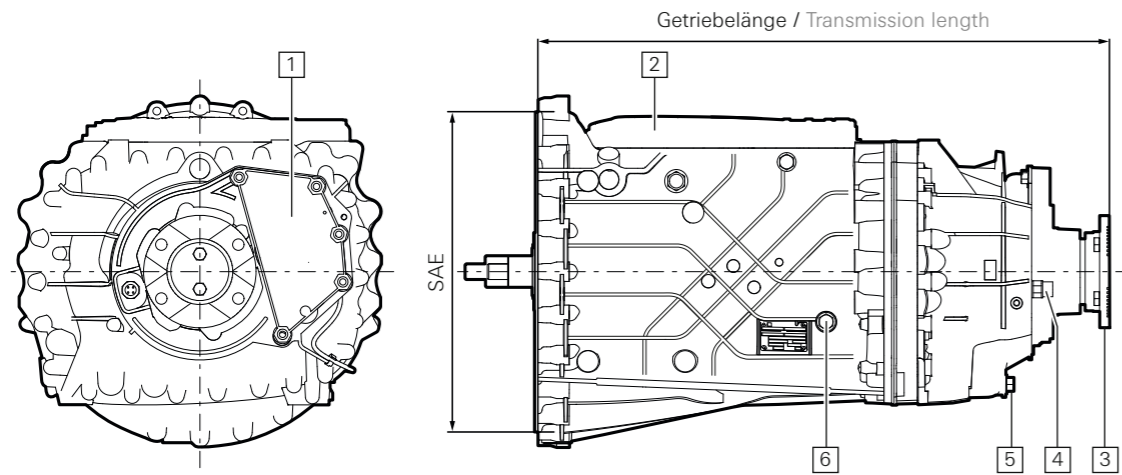

- 1 Anschluss für Nebenabtrieb / Connection for PTO
- 2 Getriebesteuerung / Transmission control unit
- 3 Abtrieb / Output
- 4 Impulsgeber / Impulse sensor
- 5 Ölablass / Oil drain
- 6 Öleinfüllung und Ölstandskontrolle / Oil fill and oil overflow check

TRAXON MIT INTARDER / TRAXON WITH INTARDER

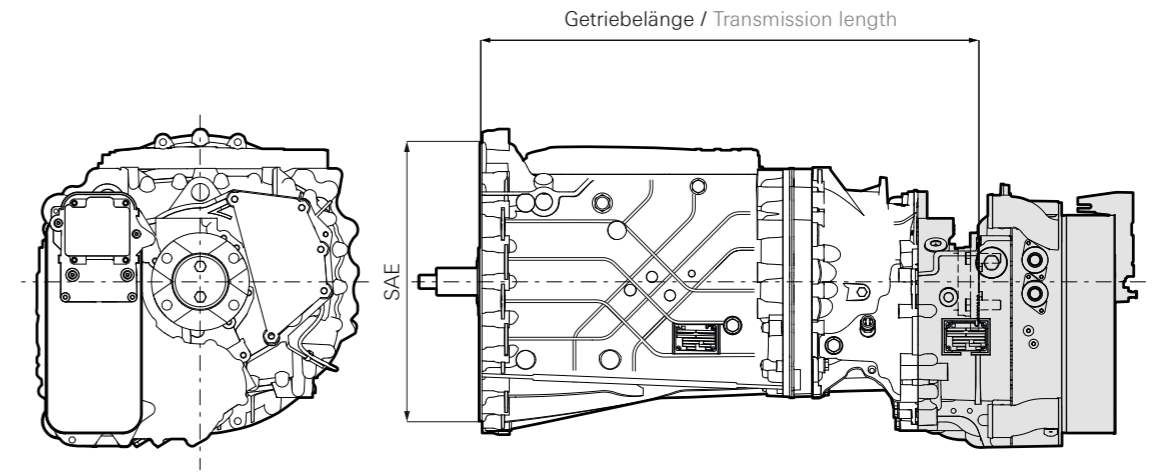

Getriebelänge mit Intarder siehe Seite 14 / Transmission length with Intarder see page 14

Getriebe-Bezeichnung	Eingangs-Drehmoment	Gangzahl	Übersetzungsbereich*	Einbau-Abmessungen	Retarder	Gewicht***	Ölfüllmenge	Nebenabtrieb
Transmission designation	Input torque	No. of gears	Ratio spread *	Installation dimensions	Retarder	Mass / weight***	Oil capacity	PTO
12 TX 1410 TD	1400 / 1033	12	16.69-1.00; R 15.54 / 12.03	1 878	○	253 335	12.5 22.5	○ ○ ○
12 TX 1610 TD	1600 / 1180	12	16.69-1.00; R 15.54 / 12.03	1 878	○	253 335	12.5 22.5	○ ○ ○
12 TX 1610 TO	1600 / 1180	12	12.92-0.77; R 12.03 / 9.29	1 878	○	253 335	12.5 22.5	○ ○ ○
12 TX 1810 TD	1800 / 1328	12	16.69-1.00; R 15.54 / 12.03	1 878	○	253 335	12.5 22.5	○ ○ ○
12 TX 1810 TO	1800 / 1328	12	12.92-0.77; R 12.03 / 9.29	1 878	○	253 335	12.5 22.5	○ ○ ○
12 TX 2010 TD	2000 / 1475	12	16.69-1.00; R 15.54 / 12.03	1 878	○	253 335	12.5 22.5	○ ○ ○
12 TX 2010 TO	2000 / 1475	12	12.92-0.77; R 12.03 / 9.29	1 878	○	253 335	12.5 22.5	○ ○ ○
12 TX 2210 TD	2200 / 1623	12	16.69-1.00; R 15.54 / 12.03	1 878	○	253 335	12.5 22.5	○ ○ ○
12 TX 2210 TO	2200 / 1623	12	12.92-0.77; R 12.03 / 9.29	1 878	○	253 335	12.5 22.5	○ ○ ○
12 TX 2420 TD	2400 / 1770	12	16.69-1.00; R 15.54 / 12.03	1 910	○	265 347	13.5 23.5	○ ○ ○
12 TX 2410 TO	2400 / 1770	12	12.92-0.77; R 12.03 / 9.29	1 878	○	253 335	12.5 22.5	○ ○ ○
12 TX 2620 TD	2600 / 1918	12	16.69-1.00; R 15.54 / 12.03	1 910	○	265 347	13.5 23.5	○ ○ ○
12 TX 2610 TO	2600 / 1918	12	12.92-0.77; R 12.03 / 9.29	1 878	○	253 335	12.5 22.5	○ ○ ○
12 TX 2820 TD	2800 / 2065	12	16.69-1.00; R 15.54 / 12.03	1 910	○	265 347	13.5 23.5	○ ○ ○
12 TX 2820 TO	2800 / 2065	12	12.92-0.77; R 12.03 / 9.29	1 910	○	265 347	13.5 23.5	○ ○ ○
12 TX 3020 TD	3000 / 2213	12	12.92-0.77; R 12.03 / 9.29	1 910	○	265 347	13.5 23.5	○ ○ ○
12 TX 3220 TO	3200 / 2360	12	12.92-0.77; R 12.03 / 9.29	1 910	○	265 347	13.5 23.5	○ ○ ○
12 TX 3420 TO	3400 / 2508	12	12.92-0.77; R 12.03 / 9.29	1 910	○	265 347	13.5 23.5	○ ○ ○

○ Option  
 \* bei allen 12 TX ... Rückwärtsgänge 3 und 4 sowie weitere Rückwärtsgangübersetzungen als Option / with all 12 TX ... optional reverse gears 3 and 4 and further rev. gear ratios  
 \*\*\* Ohne Peripherie, Kupplung und Ölfüllung / Without auxiliary, clutch and oil fill

Getriebe-Bezeichnung	Eingangs-Drehmoment	Gangzahl	Übersetzungsbereich**	Einbau-Abmessungen	Retarder	Gewicht***	Ölfüllmenge	Nebenabtrieb
Transmission designation	Input torque	No. of gears	Ratio spread**	Installation dimensions	Retarder	Mass / weight***	Oil capacity	PTO
16 TX 1640 TD	1600 / 1180	16	17.94-1.00; R 17.27 / 14.14	1 965	○	290 372	14.5 24.5	○ ○ ○
16 TX 1840 TD	1800 / 1328	16	17.94-1.00; R 17.27 / 14.14	1 965	○	290 372	14.5 24.5	○ ○ ○
16 TX 1840 TO	1800 / 1328	16	14.68-0.82; R 14.14 / 11.60	1 965	○	290 372	14.5 24.5	○ ○ ○
16 TX 2040 TD	2000 / 1475	16	17.94-1.00; R 17.27 / 14.14	1 965	○	290 372	14.5 24.5	○ ○ ○
16 TX 2040 TO	2000 / 1475	16	14.68-0.82; R 14.14 / 11.60	1 965	○	290 372	14.5 24.5	○ ○ ○
16 TX 2240 TD	2200 / 1623	16	17.94-1.00; R 17.27 / 14.14	1 965	○	290 372	14.5 24.5	○ ○ ○
16 TX 2240 TO	2200 / 1623	16	14.68-0.82; R 14.14 / 11.60	1 965	○	290 372	14.5 24.5	○ ○ ○
16 TX 2440 TD	2400 / 1770	16	17.94-1.00; R 17.27 / 14.14	1 965	○	290 372	14.5 24.5	○ ○ ○
16 TX 2440 TO	2400 / 1770	16	14.68-0.82; R 14.14 / 11.60	1 965	○	290 372	14.5 24.5	○ ○ ○
16 TX 2640 TD	2600 / 1918	16	17.94-1.00; R 17.27 / 14.14	1 965	○	290 372	14.5 24.5	○ ○ ○
16 TX 2640 TO	2600 / 1918	16	14.68-0.82; R 14.14 / 11.60	1 965	○	290 372	14.5 24.5	○ ○ ○
16 TX 2840 TD	2800 / 2065	16	17.94-1.00; R 17.27 / 14.14	1 965	○	290 372	14.5 24.5	○ ○ ○
16 TX 2840 TO	2800 / 2065	16	14.68-0.82; R 14.14 / 11.60	1 965	○	290 372	14.5 24.5	○ ○ ○
16 TX 3040 TO	3000 / 2213	16	14.68-0.82; R 14.14 / 11.60	1 965	○	290 372	14.5 24.5	○ ○ ○
16 TX 3240 TO	3200 / 2360	16	14.68-0.82; R 14.14 / 11.60	1 965	○	290 372	14.5 24.5	○ ○ ○
16 TX 3440 TO	3400 / 2508	16	14.68-0.82; R 14.14 / 11.60	1 965	○	290 372	14.5 24.5	○ ○ ○

○ Option  
 \*\* bei allen 16 TX ... Rückwärtsgänge 3 und 4 als Option / with all 16 TX ... optional reverse gears 3 and 4  
 \*\*\* Ohne Peripherie, Kupplung und Ölfüllung / Without auxiliary, clutch and oil fill

# TC TRONIC

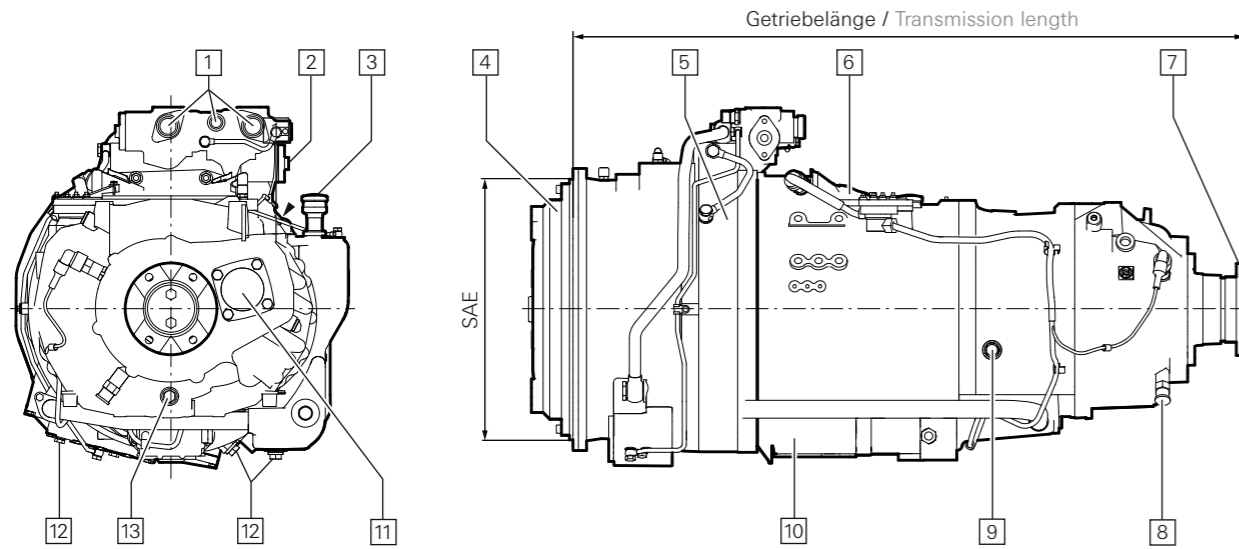

- 1 Wärmetauscheranschlüsse / Heat exchanger connections
- 2 Druckluftanschluss Retarder / Compressed air connection of Retarder
- 3 Öleinfüllung und Ölmesstab / Oil filling and oil dipstick
- 4 Hydrodynamischer Drehmomentwandler / Hydrodynamic torque converter
- 5 Primärretarder / Primary retarder
- 6 Schaltmodul / Shift module
- 7 Abtrieb / Output
- 8 Tachogegerfahrzeugeitig / Speedo sensor at vehicle end
- 9 Öleinfüllung und Ölstandskontrolle Grundgetriebe / Oil filling and oil level check of basic transmission
- 10 Kupplungsmodul / Clutch module
- 11 Anschlussstelle für kupplungsabhängigen Nebenabtrieb / Connection point for clutch-dependent PTO
- 12 Ölabblass / Oil drain
- 13 Ölabblass Grundgetriebe / Oil drain of basic transmission
- Anschlüsse der Wandlerkupplung / Connections of torque converter clutch

Getriebe-Bezeichnung	Eingangs-Drehmoment	Gangzahl	Übersetzungsbereich	Einbau-Abmessungen	Retarder	Gewicht*	Ölfüllmenge	Nebenabtrieb
Transmission designation	Input torque	No. of gears	Ratio spread	Installation dimensions	Retarder	Mass / weight*	Oil capacity	PTO
<b>12 TC 2740 TO</b>	2700 / 1993	12	12.29-0.78; R 11.38	1 1315	-	545	29.0	○ ○

○ Option  
 - nicht erhältlich / Not available  
 \* Ohne Ölfüllung / Without oil fill

# ECOTRONIC MID

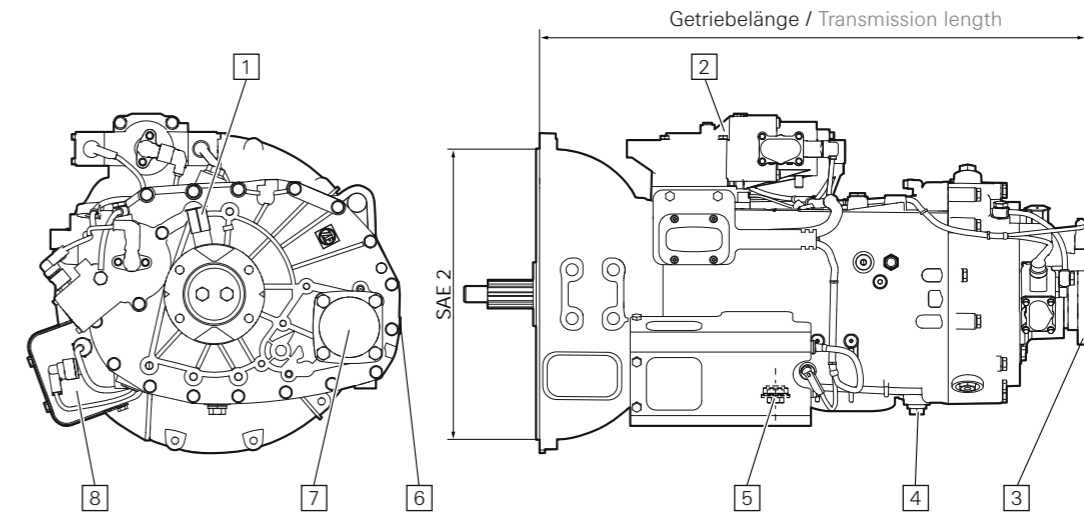

- 1 Tachogeger / Speedo sensor
- 2 Getriebesteuerung / transmission control
- 3 Abtrieb / Output
- 4 Ölabblass / Oil drain
- 5 Ölabblass / Oil drain
- 6 Öleinfüllung und Ölüberlaufmessung / Oil fill and oil overflow check
- 7 Anschlussstelle für kupplungsabhängigen Nebenabtrieb / Connection point for clutch-dependent PTO
- 8 Kupplungsmodul / Clutch module

Getriebe-Bezeichnung	Eingangs-Drehmoment	Gangzahl	Übersetzungsbereich	Einbau-Abmessungen	Retarder	Gewicht*	Ölfüllmenge	Servo-shift	Nebenabtrieb
Transmission designation	Input torque	No. of gears	Ratio spread	Installation dimensions	Retarder	Mass / weight*	Oil capacity	Servo-shift	PTO
<b>9 AS 910 TD</b>	900 / 664	9	12.73-1.00; R 12.04	2 / 1 840	-	202	8.9	○	○ ○ ○ ○
<b>9 AS 1110 TD</b>	1100 / 812	9	12.73-1.00; R 12.04	2 / 1 840	-	202	8.9	○	○ ○ ○ ○
<b>9 AS 1110 TO</b>	1100 / 812	9	9.48-0.75; R 8.97	2 / 1 840	-	202	8.9	○	○ ○ ○ ○
<b>9 AS 1310 TD</b>	1300 / 959	9	12.73-1.00; R 12.04	2 / 1 840	-	202	8.9	○	○ ○ ○ ○
<b>9 AS 1310 TO</b>	1300 / 959	9	9.48-0.75; R 8.97	2 / 1 840	-	202	8.9	○	○ ○ ○ ○
<b>9 AS 1510 TO</b>	1500 / 1106	9	9.48-0.75; R 8.97	2 / 1 840	-	202	8.9	○	○ ○ ○ ○

○ Option  
 - nicht erhältlich / Not available  
 \* Ohne Ölfüllung / Without oil fill

# AS TRONIC MID

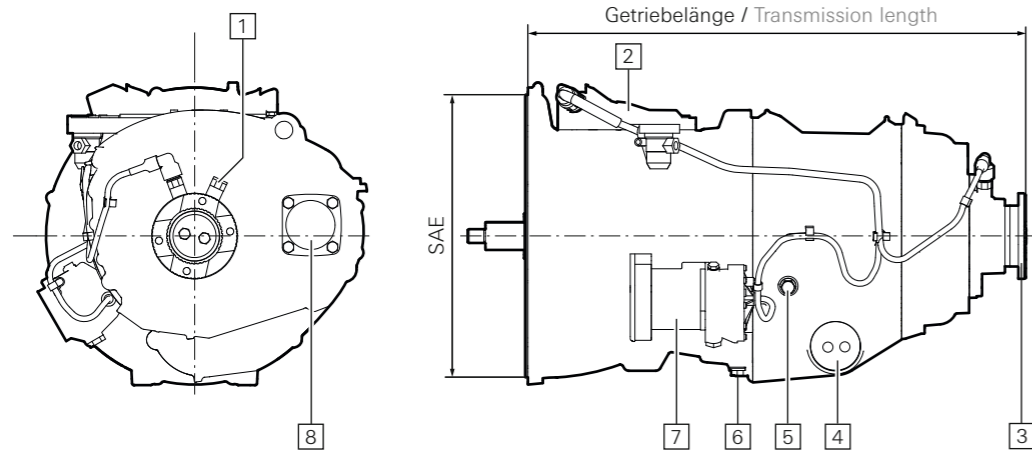

- 1 Tachogeber / Speedo sensor
- 2 Schaltmodul / Shift module
- 3 Abtrieb / Output
- 4 Wärmetauscher (Option, anwendungsspezifisch) / Heat exchanger (optional, application specific)
- 5 Öleinfüllung und Ölüberlaufmessung / Oil fill and oil overflow check
- 6 Ölablass / Oil drain
- 7 Kupplungsmodul / Clutch module
- 8 Anschlussstelle für kupplungsabhängigen Nebenabtrieb / Connection point for clutch-dependent PTO

Getriebe-Bezeichnung Transmission designation	Eingangs-Drehmoment Input torque	Gangzahl No. of gears	Übersetzungsbereich Ratio spread	Einbau-Abmessungen Installation dimensions	Retarder	Gewicht* Mass / weight*	Ölfüllmenge Oil capacity	Nebenabtrieb PTO
12 AS 1010 TD	1000 / 738	12	12.84-1.00; R 13.07	1 / 2 840	-	183	7.8	○ ○ ○
12 AS 1010 TO	1000 / 738	12	10.37-0.81; R 10.56	1 / 2 840	-	183	7.8	○ ○ ○
12 AS 1210 TO	1200 / 886	12	10.37-0.81; R 10.56	1 / 2 840	-	183	7.8	○ ○ ○
12 AS 1220 TD	1200 / 886	12	12.84-1.00; R 13.07	1 / 2 900	-	201	9.3	○ ○ ○
12 AS 1420 TD	1400 / 1033	12	12.84-1.00; R 13.07	1 / 2 900	-	201	9.3	○ ○ ○
12 AS 1420 TO	1400 / 1033	12	10.37-0.81; R 10.56	1 / 2 900	-	201	9.3	○ ○ ○
12 AS 1620 TO	1600 / 1181	12	10.37-0.81; R 10.56	1 / 2 900	-	201	9.3	○ ○ ○

○ Option  
 - nicht erhältlich / Not available  
 \* Ohne Ölfüllung / Without oil fill

# AS TRONIC LITE

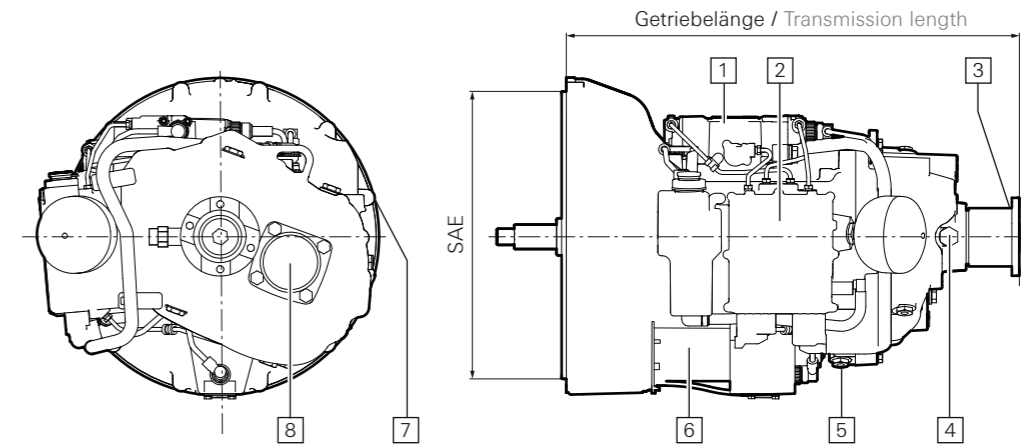

- 1 Getriebesteller / Transmission actuator
- 2 Powerpack mit integrierter Getriebesteuerung / Powerpack with integrated transmission control (electronic control unit)
- 3 Abtrieb / Output
- 4 Tachogeber / Speedo sensor
- 5 Ölablass / Oil drain
- 6 Kupplungssteller / Clutch actuator
- 7 Öleinfüllung und Ölüberlaufmessung / Oil fill and oil overflow check
- 8 Anschlussstelle für kupplungsabhängigen Nebenabtrieb / Connection point for clutch-dependent PTO

Getriebe-Bezeichnung Transmission designation	Eingangs-Drehmoment Input torque	Gangzahl No. of gears	Übersetzungsbereich Ratio spread	Einbau-Abmessungen Installation dimensions	Retarder	Gewicht* Mass / weight*	Ölfüllmenge Oil capacity	Nebenabtrieb PTO
6 AS 700 TO	700 / 516	6	6.02-0.79; R 5.58	2 709	-	119	6.0	○ -
6 AS 800 TO	850 / 627	6	6.58-0.78; R 6.06	2 709	-	140	9.8	○ -
6 AS 1000 TO	1050 / 774	6	6.75-0.78; R 6.06	2 709	-	152	9.3	○ -

○ Option  
 - nicht erhältlich / Not available  
 \* Ohne Ölfüllung / Without oil fill

# ECOSPLIT

# ECOMID

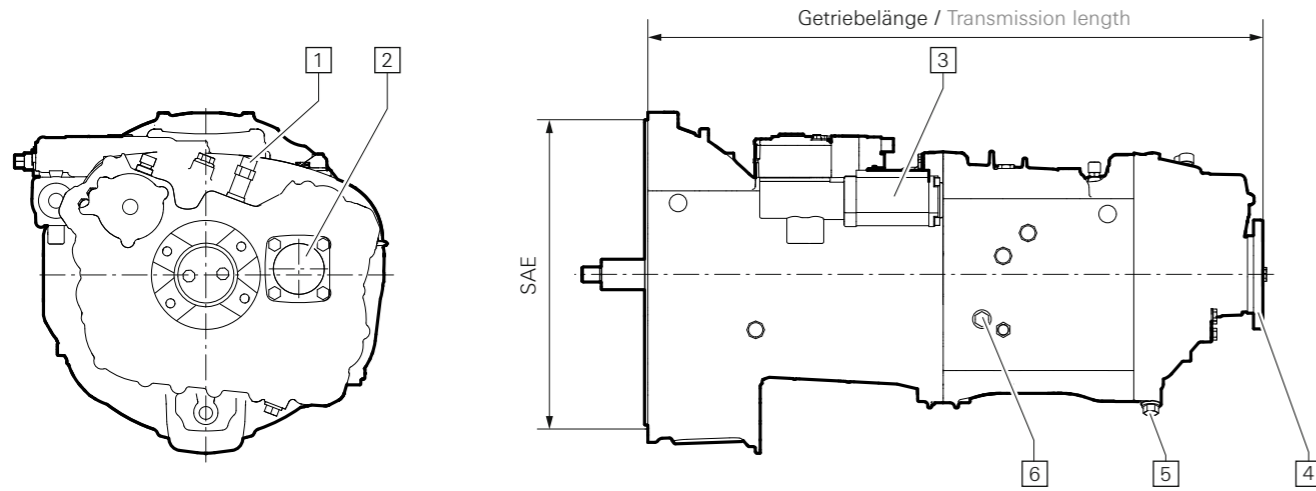

- 1 Tachogeberanschluss, elektronisch (wahlweise) / Speedometer connection, electronic (optional)
- 2 Anschlussstelle für kupplungsabhängige Nebenabtriebe / Connection point for clutch-dependent PTOs
- 3 Servoshift / Servoshift
- 4 Abtrieb / Output
- 5 Ölablass / Oil drain
- 6 Öleinfüllung und Ölüberlaufmessung / Oil fill and oil overflow check

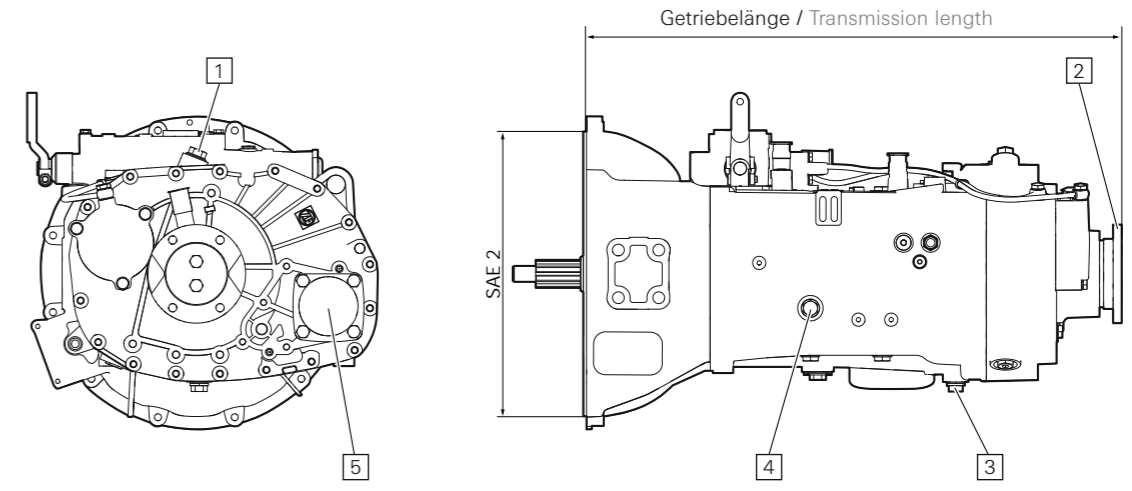

- 1 Tachogeber / Speedo sensor
- 2 Abtrieb / Output
- 3 Ölablass / Oil drain
- 4 Öleinfüllung und Ölüberlaufmessung / Oil fill and oil overflow check
- 5 Anschlussstelle für kupplungsabhängige Nebenabtriebe / Connection point for clutch-dependent PTOs

Getriebe-Bezeichnung	Eingangs-Drehmoment	Gang-zahl	Übersetzungs-bereich	Einbau-Abmessungen	Retarder	Gewicht*	Ölfüllmenge	Servo-shift	Nebenabtrieb
Transmission designation	Input torque	No. of gears	Ratio spread	Installation dimensions	Retarder	Mass / weight*	Oil capacity	Servo-shift	PTO
					ZF-Intarder	+ZF-Intarder	+ZF-Intarder		
	Nm / Lb / ft			SAE mm		kg	Liter / Litre		NMV N1 / 4 / 10 N-PL
12 S 2130 TD	2100 / 1550	12	15.57-1.00; R 14.57	1 930	○	277 350	13.4 23.0	○	○ ○ ○ ○
12 S 2330 TD	2300 / 1697	12	15.57-1.00; R 14.57	1 1015	○	307 380	15.4 25.0	○	○ ○ ○ ○
12 S 2833 TD	2800 / 2066	12	15.57-1.00; R 14.57	1 1015	○	307 380	15.4 25.0	○	○ ○ ○ ○
16 S 1630 TD	1600 / 1181	16	16.41-1.00; R 15.36	1 930	○	278 351	13.4 23.0	○	○ ○ ○ ○
16 S 1830 TD	1850 / 1365	16	13.80-0.84; R 12.92	1 930	○	278 351	13.4 23.0	○	○ ○ ○ ○
16 S 1930 TD	1900 / 1402	16	16.41-1.00; R 15.36	1 1015	○	306 379	15.4 25.0	○	○ ○ ○ ○
16 S 2230 TO	2200 / 1624	16	13.80-0.84; R 12.92	1 1015	○	306 379	15.4 25.0	○	○ ○ ○ ○
16 S 2230 TD	2200 / 1624	16	16.41-1.00; R 15.36	1 1015	○	314 387	15.4 25.0	○	○ ○ ○ ○
16 S 2330 TD	2350 / 1734	16	16.41-1.00; R 15.36	1 1015	○	314 387	15.4 25.0	○	○ ○ ○ ○
16 S 2530 TO	2500 / 1845	16	13.80-0.84; R 12.92	1 1015	○	314 387	15.4 25.0	○	○ ○ ○ ○
16 S 2730 TO	2700 / 1993	16	13.80-0.84; R 12.92	1 1031	○	331 404	15.4 25.0	○	○ ○ ○ ○

○ Option  
 - nicht erhältlich / Not available  
 \* Ohne Ölfüllung / Without oil fill

Alle Ecosplit-Getriebetypen 1x S xx3x Tx sind auch mit Zusatzwärmetauscher lieferbar. / All Ecosplit transmission types 1x S xx3x Tx are also available with additional heat exchanger.

Getriebe-Bezeichnung	Eingangs-Drehmoment	Gang-zahl	Übersetzungs-bereich	Einbau-Abmessungen	Retarder	Gewicht*	Ölfüllmenge	Servo-shift	Nebenabtrieb
Transmission designation	Input torque	No. of gears	Ratio spread	Installation dimensions	Retarder	Mass / weight*	Oil capacity	Servo-shift	PTO
					ZF-Intarder	+ZF-Intarder	+ZF-Intarder		
	Nm / Lb / ft			SAE mm		kg	Liter / Litre		NMV N1 / 4 / 10 N-PL
9 S 910 TD	900 / 664	9	12.73-1.00; R 12.04	2 / 1 840	○	190 260	8.9 24.1	○	○ ○ ○ ○
9 S 1110 TD	1100 / 812	9	12.73-1.00; R 12.04	2 / 1 840	○	190 260	8.9 24.1	○	○ ○ ○ ○
9 S 1110 TO	1100 / 812	9	9.48-0.75; R 8.97	2 / 1 840	○	190 260	8.9 24.1	○	○ ○ ○ ○
9 S 1310 TD	1300 / 959	9	12.73-1.00; R 12.04	2 / 1 840	○	190 260	8.9 24.1	○	○ ○ ○ ○
9 S 1310 TO	1300 / 959	9	9.48-0.75; R 8.97	2 / 1 840	○	190 260	8.9 24.1	○	○ ○ ○ ○
9 S 1510 TO	1500 / 1106	9	9.48-0.75; R 8.97	2 / 1 840	○	190 260	8.9 24.1	○	○ ○ ○ ○

○ Option  
 - nicht erhältlich / Not available  
 \* Ohne Ölfüllung / Without oil fill

# ECOLITE

## FÜR LEICHTE LKW / FOR LIGHT TRUCKS

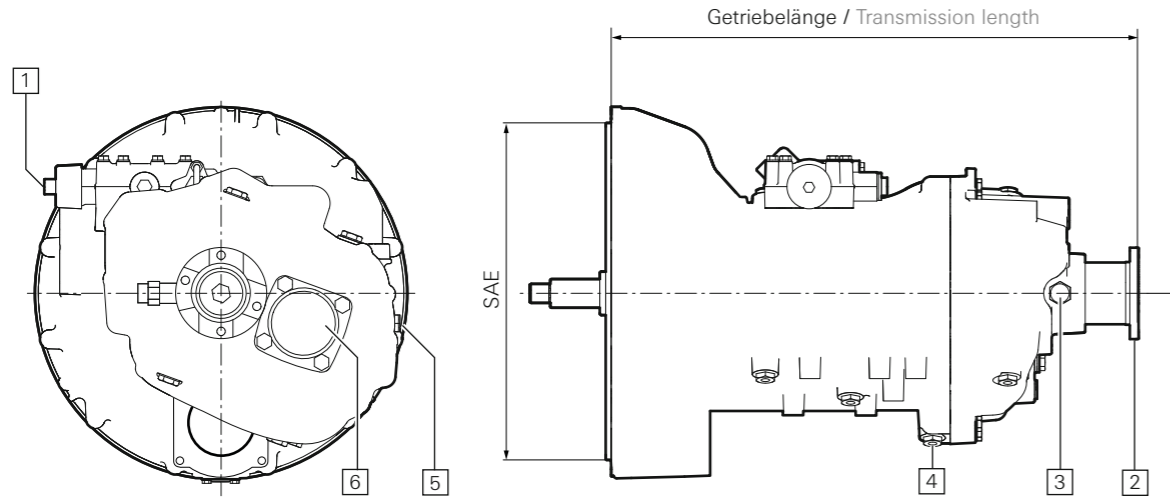

- 1 Schaltabgang / Selector output
- 2 Abtrieb / Output
- 3 Tachogeber / Speedo sensor
- 4 Ölablass / Oil drain
- 5 Öleinfüllung und Ölüberlaufmessung / Oil fill and oil overflow check
- 6 Anschlussstelle für kupplungsabhängige Nebenabtriebe / Connection point for clutch-dependent PTOs

Getriebe-Bezeichnung	Eingangs-Drehmoment	Gang-zahl	Übersetzungs-bereich	Einbau-Abmessungen	Retarder	Gewicht*	Ölfüllmenge	Servo-shift	Nebenabtrieb
Transmission designation	Input torque	No. of gears	Ratio spread	Installation dimensions	Retarder	Mass / weight*	Oil capacity	Servo-shift	PTO
6 S 700 TO	700 / 516	6	6.02-0.79; R 5.58	2 709	-	103	6.0	○	○
6 S 800 TO	850 / 627	6	6.58-0.78; R 6.06	2 709	-	124	9.8	○	○
6 S 1000 TO	1050 / 774	6	6.75-0.78; R 6.06	2 709	-	136	9.3	○	○

○ Option  
 - nicht erhältlich / Not available  
 \* Ohne Ölfüllung / Without oil fill

# ECOLITE

## FÜR VAN UND PICKUP / FOR VAN AND PICKUP

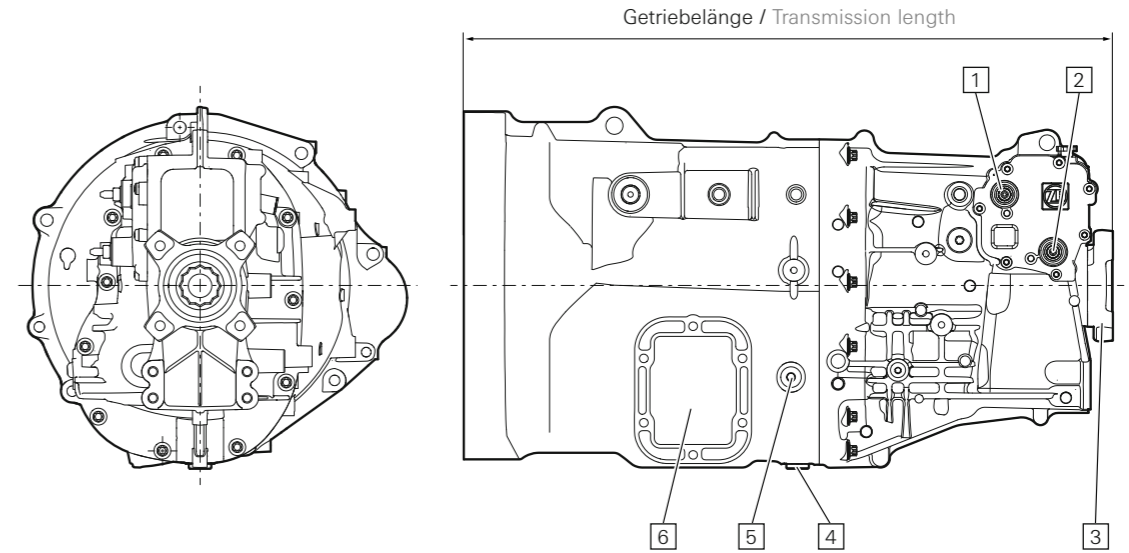

- 1 Anschluss für Wählhebel / Gear selection lever connection
- 2 Anschluss für Schalthebel / Gear shift lever connection
- 3 Abtrieb / Output
- 4 Ölablass / Oil drain
- 5 Öleinfüllung und Ölüberlaufmessung / Oil fill and oil overflow check
- 6 Anschlussstelle für kupplungsabhängige Nebenabtriebe / Connection point for clutch-dependent PTOs

Getriebe-Bezeichnung	Eingangs-Drehmoment	Gang-zahl	Übersetzungs-bereich	Einbau-Abmessungen	Gewicht*	Ölfüllmenge	Kupplungs-glocke	Schaltung	Park-bremse	PTO
Transmission designation	Input torque	No. of gears	Ratio spread	Installation dimensions	Mass / weight*	Oil capacity	CBH	Actuation	Park. brake	PTO
6 S 350 V	350 / 258	6	6.73-1.00; R 6.01	- 430* 658	63	2.7	- ●	○ - ○ ●	○	○
6 S 380 V	380 / 280	6	5.38-0.79; R 4.84	- 475* 658	63	2.2	- ●	○ - ○ ●	○	○
6 S 400 V	400 / 295	6	5.38-0.79; R 4.84	- 475* 658	63	2.2	- ●	○ - ○ ●	○	○
6 S 420 V	420 / 310	6	5.78-0.79; R 5.24	- 490* 658	63	2.2	- ●	○ - ○ ●	○	○
6 S 420 V	420 / 310	6	5.54-0.72; R 5.02	- 490* 658	63	2.2	- ●	○ - ○ ●	○	○
6 S 450 P	450 / 332	6	4.82-0.64; R 4.37	- 287 690	61	1.5	- ●	- - ● ○	-	-
6 S 480 P	500 / 370	6	5.07-0.65; R 4.82	- 310* 675	56	1.8	- ●	○ ○ ● ○	○	○
6 S 480 V	500 / 370	6	5.07-0.65; R 4.82	3 310* 675	56	1.8	- ●	○ ○ ○ ●	○	○

● Standard  
 ○ Option  
 - nicht erhältlich / Not available  
 \* Je nach Ausführung, kundenspezifisch / Depending on version, customer-specific

# INTARDER FÜR TRAXON / FOR TRAXON

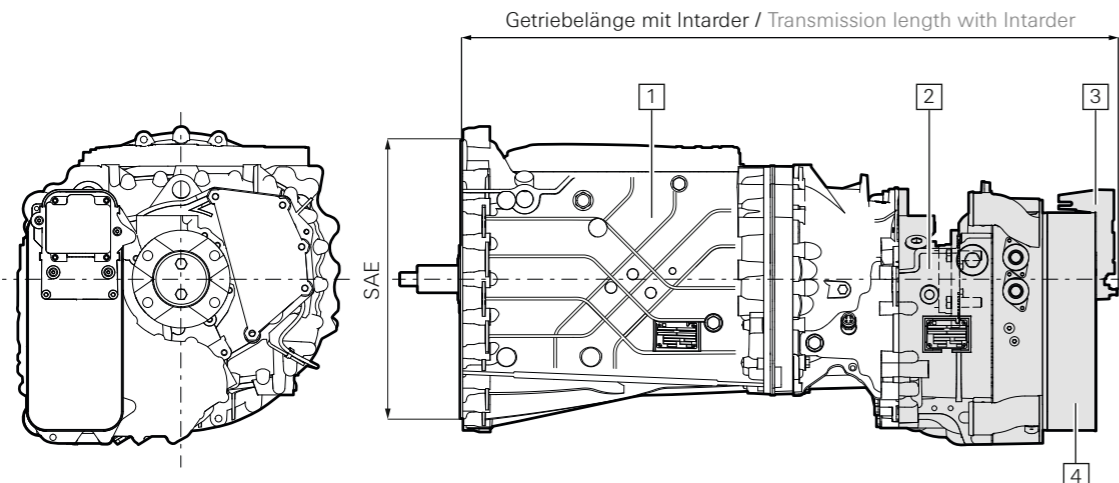

- 1 TraXon-Getriebe / TraXon transmission
- 2 Intarder-Einheit / Intarder unit
- 3 Intardersteuerung / Intarder control unit
- 4 Öl-/Wasser-Wärmetauscher / Oil/water heat exchanger

Getriebe-Bezeichnung Transmission designation	Einbau-Abmessungen Installation dimensions	Zusatzgewicht Intarder <sup>1)</sup> kg	Zusätzliche Ölmenge Liter / Litre
	+ZF-Intarder mm	kg	Liter / Litre
12 TX ..11 TD/TO	1170	82	10
12 TX ..21 TD/TO	1202	82	10
16 TX ..41 TD/TO	1257	82	10

1) Mehrgewicht gegenüber Standardgetriebe: inkl. Adaptergehäuse, Wärmetauscher, Ölspeicher; ohne Öl und Wasser. / Additional weight of Intarder in addition to transmission (includes adaptation housing, heat exchanger, oil reservoir; without oil or water)

## INTARDERFUNKTIONEN

- **Bremsomat – Standardfunktion**  
Selbsttätige Regelung der Bremsleistung auf eine vorgewählte konstante Fahrgeschwindigkeit im Gefälle
- **Bremsomatic (incl. Tempomat) – Option**  
Wie Bremsomatbetrieb; zusätzlich wird bei veränderter Fahrgeschwindigkeit das neue Tempo abgespeichert. Die gesetzte Geschwindigkeit wird auch in der Ebene und am Berg konstant gehalten.

## INTARDER FUNCTIONS

- **Bremsomat – standard function**  
Automatic braking power regulation to maintain a preselected vehicle speed on downhill gradients
- **Bremsomatic (incl. Tempomat) – option**  
Similar to Bremsomat operation; in addition, the new speed is stored when the vehicle speed has changed. The speed set will then be maintained on level roads and when going uphill.

# INTARDER FÜR ECOSPLIT / FOR ECOSPLIT

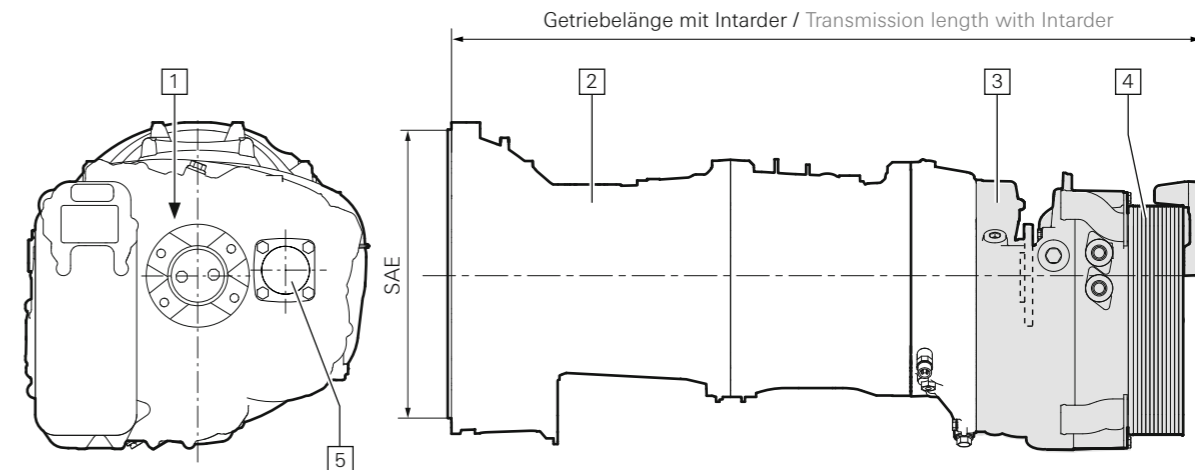

- 1 Anschlussmöglichkeit für Lenkumpenantrieb / Option for steering pump drive
- 2 Ecosplit-Getriebe / Ecosplit transmission
- 3 Intarder-Einheit / Intarder unit
- 4 Öl-/Wasser-Wärmetauscher / Oil/water heat exchanger
- 5 Anschluss für Nebenabtrieb / Connection for PTO

Getriebe-Bezeichnung Transmission designation	Einbau-Abmessungen Installation dimensions	Zusatzgewicht Intarder <sup>1)</sup> kg	Zusätzliche Ölmenge Liter / Litre
	+ZF-Intarder mm	kg	Liter / Litre
12 S 2131 TD	1235	70	10
12 S 2331 TD	1318	70	10
12 S 2831 TD	1318	70	10
16 S 1631 TD	1235	70	10
16 S 1831 TO	1235	70	10
16 S 1931 TD	1318	70	10
16 S 2231 TO	1318	70	10
16 S 2231 TD	1318	70	10
16 S 2331 TD	1318	70	10
16 S 2531 TO	1318	70	10
16 S 2731 TO	1333	70	10

1) Mehrgewicht gegenüber Standardgetriebe: inkl. Adaptergehäuse, Wärmetauscher, Ölspeicher; ohne Öl und Wasser. / Additional weight of Intarder in addition to transmission (includes adaptation housing, heat exchanger, oil reservoir; without oil or water)

## INTARDERFUNKTIONEN

- **Bremsomat – Standardfunktion**  
Selbsttätige Regelung der Bremsleistung auf eine vorgewählte konstante Fahrgeschwindigkeit im Gefälle
- **Bremsomatic (incl. Tempomat) – Option**  
Wie Bremsomatbetrieb; zusätzlich wird bei veränderter Fahrgeschwindigkeit das neue Tempo abgespeichert. Die gesetzte Geschwindigkeit wird auch in der Ebene und am Berg konstant gehalten.

## INTARDER FUNCTIONS

- **Bremsomat – standard function**  
Automatic braking power regulation to maintain a preselected vehicle speed on downhill gradients
- **Bremsomatic (incl. Tempomat) – option**  
Similar to Bremsomat operation; in addition, the new speed is stored when the vehicle speed has changed. The speed set will then be maintained on level roads and when going uphill.



# INTARDER

## FÜR ECOMID / FOR ECOMID

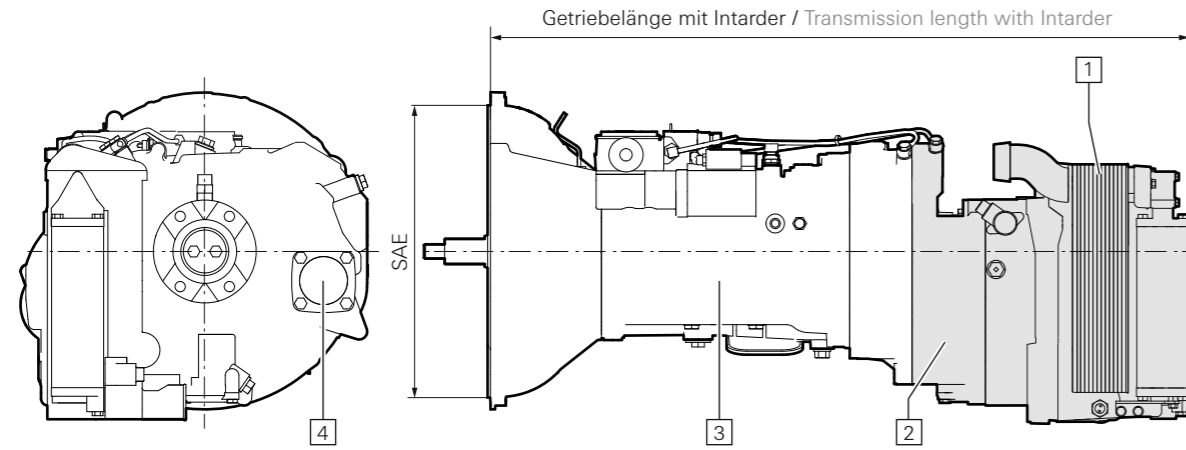

- 1 Öl-/Wasser-Wärmetauscher / Oil/water heat exchanger
- 2 Intarder-Einheit / Intarder unit
- 3 Ecomid-Getriebe / Ecomid transmission
- 4 Anschluss für Nebenabtrieb / Connection for PTO

Getriebe-Bezeichnung Transmission designation	Einbau-Abmessungen Installation dimensions	Zusatzgewicht Intarder <sup>1)</sup> kg	Zusätzliche Ölmenge Liter / Litre
9 S 911 TD	1222	71	15
9 S 1111 TD	1222	71	15
9 S 1111 TO	1222	71	15
9 S 1311 TD	1222	71	15
9 S 1311 TO	1222	71	15
9 S 1511 TO	1222	71	15

<sup>1)</sup> Mehrgewicht gegenüber Standardgetriebe: inkl. Adaptergehäuse, Wärmetauscher, Ölspeicher; ohne Öl und Wasser. / Additional weight of Intarder in addition to transmission (includes adaptation housing, heat exchanger, oil reservoir; without oil or water)

### INTARDERFUNKTIONEN

- **Bremsomat – Standardfunktion**  
Selbsttätige Regelung der Bremsleistung auf eine vorgewählte konstante Fahrgeschwindigkeit im Gefälle
- **Bremsomatic (incl. Tempomat) – Option**  
Wie Bremsomatbetrieb; zusätzlich wird bei veränderter Fahrgeschwindigkeit das neue Tempo abgespeichert. Die gesetzte Geschwindigkeit wird auch in der Ebene und am Berg konstant gehalten.

### INTARDER FUNCTIONS

- **Bremsomat – standard function**  
Automatic braking power regulation to maintain a preselected vehicle speed on downhill gradients
- **Bremsomatic (incl. Tempomat) – option**  
Similar to Bremsomat operation; in addition, the new speed is stored when the vehicle speed has changed. The speed set will then be maintained on level roads and when going uphill.

# NEBENABTRIEBE / POWER TAKE-OFFS (PTO)

## AUTOMATISIERTE GETRIEBE / AUTOMATED TRANSMISSIONS

Getriebe-Bezeichnung	Nebenabtriebstyp	Abtriebsstelle	Abtriebsmoment <sup>(8)</sup> (Nm)	Drehzahlfaktor		Drehrichtung		Antrieb durch			Betriebsart		
				Speed factor		Output rotation		Driven by			Operation		
				*f* <sup>(1)</sup>	*g* <sup>(2)</sup>	entgegen Motor counter-engine wise	wie Motor engine wise	kupplungsabhängig clutch-dependent	motorabhängig engine-dependent	fahrbahngängig road driven	Dauer- <sup>(3)</sup> betrieb continuous operation	Kurzzeitbetrieb intermittend operation	
TraXon 12 TX 1410 TD 12 TX 1610 TD 12 TX 1810 TD 12 TX 2010 TD 12 TX 2210 TD 12 TX 2420 TD 12 TX 2620 TD 12 TX 2820 TD	NH/1		1000	0.76	-	●	-	●	-	-	●	-	
	NH/4		430	0.68 - 0.97	-	-	●	-	-	-	-	●	
	N TX/10	1 <sup>(5)</sup>	360 - 580	0.97 - 1.94	-	-	●	-	-	-	●	-	
		2 <sup>(6)</sup>	630 - 720	0.69 - 1.19	-	-	●	-	-	-	●	-	
	NH/PL NMV 1600 L1 <sup>(4)</sup> NMV 2000 L1 <sup>(4)</sup>					1.85	-	-	●	-	●	-	
		12 Uhr	1600	1.54	-	-	●	-	●	-	●	-	
		12 Uhr	2000	1.21	-	-	●	-	●	-	●	-	
	TraXon 12 TX 1610 TO 12 TX 1810 TO 12 TX 2010 TO 12 TX 2210 TO 12 TX 2410 TO 12 TX 2610 TO 12 TX 2820 TO 12 TX 3020 TO 12 TX 3220 TO 12 TX 3420 TO	NH/1		1000	1.26	-	●	-	●	-	-	●	-
		NH/4		430	0.88 - 1.14	-	-	●	-	-	-	-	●
		N TX/10	1 <sup>(5)</sup>	490 - 600	1.31 - 2.01	-	-	●	-	-	-	●	-
			2 <sup>(6)</sup>	690 - 730	0.96 - 1.56	-	-	●	-	-	-	●	-
		NH/PL NMV 1600 L1 <sup>(4)</sup> NMV 2000 L1 <sup>(4)</sup>					1.85	-	-	●	-	●	-
12 Uhr			1600	1.54	-	-	●	-	●	-	●	-	
		12 Uhr	2000	1.21	-	-	●	-	●	-	●	-	
TraXon 16 TX 1640 TD 16 TX 1840 TD 16 TX 2040 TD 16 TX 2240 TD 16 TX 2440 TD 16 TX 2640 TD 16 TX 2840 TD		NH/1		1000	0.72	-	●	-	●	-	-	●	-
		NH/4		430	0.65 - 0.93	-	-	●	-	-	-	-	●
		N TX/10	1 <sup>(5)</sup>	360 - 580	0.93 - 1.85	-	-	●	-	-	-	●	-
			2 <sup>(6)</sup>	630 - 720	0.66 - 1.14	-	-	●	-	-	-	●	-
		NH/PL NMV 1600 L1 <sup>(4)</sup> NMV 2000 L1 <sup>(4)</sup>					1.85	-	-	●	-	●	-
	12 Uhr		1600	1.54	-	-	●	-	●	-	●	-	
		12 Uhr	2000	1.21	-	-	●	-	●	-	●	-	
	TraXon 16 TX 1840 TO 16 TX 2040 TO 16 TX 2240 TO 16 TX 2440 TO 16 TX 2640 TO 16 TX 2840 TO 16 TX 3040 TO 16 TX 3240 TO 16 TX 3440 TO	NH/1		1000	1.08	-	●	-	●	-	-	●	-
		NH/4		430	0.80 - 1.13	-	-	●	-	-	-	-	●
		N TX/10	1 <sup>(5)</sup>	430 - 600	1.12 - 1.99	-	-	●	-	-	-	●	-
			2 <sup>(6)</sup>	690 - 730	0.82 - 1.33	-	-	●	-	-	-	●	-
		NH/PL NMV 1600 L1 <sup>(4)</sup> NMV 2000 L1 <sup>(4)</sup>					1.85	-	-	●	-	●	-
12 Uhr			1600	1.54	-	-	●	-	●	-	●	-	
		12 Uhr	2000	1.21	-	-	●	-	●	-	●	-	
TC-Tronic 12 TC 2740 TO		NH/1		1000	1.35	-	●	-	●	-	-	●	-
		NH/4		430	1.22	-	-	●	-	-	-	-	●
		N AS/10	1 <sup>(5)</sup>	490 - 600	1.40 - 2.15	-	-	●	-	-	-	●	-
			2 <sup>(6)</sup>	710 - 730	1.03 - 1.48	-	-	●	-	-	-	●	-
N AS/PL			-	-	1.85	-	-	●	-	-	●	-	

- Standard
  - Nicht erhältlich / Not available
- (1) = Abtriebsdrehzahl = f x Motordrehzahl / Output speed = f x engine speed  
 (2) = Pumpendrehzahl = g x Abtriebsdrehzahl des Getriebes / Pump speed = g x output speed of transmission  
 (3) = Für Dauerbetrieb muss grundsätzlich beim Ersteinbau eine Öltemperaturmessung durchgeführt werden. Wird die max. zul. Temperatur überschritten, muss eine Zusatzkühlung eingebaut werden / Initial installation for continuous operation invariably requires measurement of the oil temperature. If the maximally permitted temperature is exceeded, an additional cooling system must be installed.  
 (4) = Anschluss motor- und getriebeseitig SAE 1. Der NMV ist außerdem für weitere ZF-Getriebe mit Motoranschluss SAE 1 sowie für Getriebe anderer Hersteller geeignet. / Connection to engine and to transmission SAE 1. NMV is also suitable for other ZF transmissions with SAE 1 engine connection and for non-ZF transmissions.  
 (5) = Schneller Abtrieb / Fast output  
 (6) = Langsamer Abtrieb / Slow output  
 (7) = Installation nur möglich bei einem Durchmesser des Getriebeabtriebsflansches bis max. 120 mm / Installation only possible with transmission output flange diameter not exceeding 120 mm  
 (8) = Bei Kombination von Nebenabtrieben ist Rücksprache mit ZF erforderlich / If PTOs shall be combined, consultation with ZF is required

# NEBENABTRIEBE / POWER TAKE-OFFS (PTO)

## AUTOMATISIERTE GETRIEBE / AUTOMATED TRANSMISSIONS

Getriebe-Bezeichnung	Nebenabtriebstyp	Abtriebsstelle	Abtriebsmoment <sup>(8)</sup> (Nm)	Drehzahlfaktor		Drehrichtung		Antrieb durch			Betriebsart		
				Speed factor		Output rotation		Driven by			Operation		
				*f* <sup>(1)</sup>	*g* <sup>(2)</sup>	entgegen Motor counter-engine wise	wie Motor engine wise	kupplungsabhängig clutch-dependent	motorabhängig engine-dependent	fahrbahngängig road driven	Dauer- <sup>(3)</sup> betrieb continuous operation	Kurzzeitbetrieb intermittend operation	
EcoTronic mid 9 AS 910 TD 9 AS 1110 TD 9 AS 1310 TD	NH/1		800	0.72	-	●	-	●	-	-	●	-	
	NH/4		430	0.92	-	-	●	●	-	-	-	●	
	N 109/10	C	410 - 630	0.88 - 1.42	-	-	●	●	-	-	●	-	
		D: NL/1	600	0.72	-	-	●	-	-	-	●	-	
		D: NL/4	430	0.92	-	-	●	-	-	-	-	●	
	N 109/PL NMV 1600 L1 <sup>(4)</sup> NMV 2000 L1 <sup>(4)</sup>					1.85	-	-	●	-	●	-	
		12 Uhr	1600	1.54	-	-	●	-	●	-	●	-	
		12 Uhr	2000	1.21	-	-	●	-	●	-	●	-	
	EcoTronic mid 9 AS 1110 TO 9 AS 1310 TO 9 AS 1510 TO	NH/1		800	0.97	-	●	-	●	-	-	●	-
		NH/4		430	1.24	-	-	●	●	-	-	-	●
		N 109/10	C	410 - 630	1.19 - 1.90	-	-	●	●	-	-	●	-
			D: NL/1	600	0.97	-	-	●	-	-	-	●	-
		D: NL/4	430	1.24	-	-	●	●	-	-	-	●	
N 109/PL NMV 1600 L1 <sup>(4)</sup> NMV 2000 L1 <sup>(4)</sup>						1.85	-	-	●	-	●	-	
		12 Uhr	1600	1.54	-	-	●	-	●	-	●	-	
		12 Uhr	2000	1.21	-	-	●	-	●	-	●	-	
AS Tronic mid 12 AS 1010 TD 12 AS 1220 TD 12 AS 1420 TD		NH/1		800	0.80 / 0.99	-	●	-	●	-	-	●	-
		NH/4		430	1.02 / 1.27	-	-	●	●	-	-	-	●
		NM AS/10	C	380 - 590	0.99 - 2.17	-	-	●	●	-	-	●	-
			D: NL/1	600	0.80 / 0.99	-	-	●	-	-	-	●	-
		D: NL/4	430	1.02 / 1.27	-	-	●	●	-	-	-	●	
	NM AS/PL NMV 1600 L1 <sup>(4)</sup> NMV 2000 L1 <sup>(4)</sup>					1.85	-	-	●	-	●	-	
		12 Uhr	1600	1.54	-	-	●	-	●	-	●	-	
		12 Uhr	2000	1.21	-	-	●	-	●	-	●	-	
	AS Tronic mid 12 AS 1010 TO 12 AS 1210 TO 12 AS 1420 TO 12 AS 1620 TO	NH/1		800	0.99 / 1.22	-	●	-	●	-	-	●	-
		NH/4		430	0.89 / 1.10	-	-	●	●	-	-	-	●
		NM AS/10	C	380 - 590	1.22 - 2.33	-	-	●	●	-	-	●	-
			D: NL/1	600	0.99 / 1.22	-	-	●	-	-	-	●	-
		D: NL/4	430	0.89 / 1.10	-	-	●	●	-	-	-	●	
NM AS/PL NMV 1600 L1 <sup>(4)</sup> NMV 2000 L1 <sup>(4)</sup>						1.85	-	-	●	-	●	-	
		12 Uhr	1600	1.54	-	-	●	-	●	-	●	-	
		12 Uhr	2000	1.21	-	-	●	-	●	-	●	-	
AS Tronic lite 6 AS 700 TO		NL/1 <sup>(7)</sup>		600	0.57	-	●	-	●	-	-	●	-
		NL/4		430	0.73	-	-	●	●	-	-	-	●
		NL/6		400	1.10	-	-	●	●	-	-	-	●
		NH/1 <sup>(7)</sup>		800	0.53	-	-	●	-	●	-	-	●
	NH/4			430	0.67	-	-	●	●	-	-	-	●
	AS Tronic lite 6 AS 800 TO	NH/6		400	1.01	-	-	●	●	-	-	-	●
NH/1				1000	0.53	-	-	●	-	-	-	●	
NH/4			430	0.67	-	-	●	●	-	-	-	●	
			270 - 480	1.19 - 2.03	-	-	●	●	-	-	●	-	
NL/10		D: NL/1	600	0.53	-	-	●	-	●	-	-	●	
		D: NL/4	430	0.67	-	-	●	●	-	-	-	●	

# NEBENABTRIEBE / POWER TAKE-OFFS (PTO)

## MANUELLE GETRIEBE / MANUAL TRANSMISSIONS

Getriebe- Bezeichnung	Nebenab- triebtyp	Abtriebs- stelle	Abtriebsmo- ment <sup>(8)</sup> (Nm)	Drehzahlfaktor		Drehrichtung		Antrieb durch			Betriebsart		
				Speed factor		Output rotation		Driven by			Operation		
				"f" <sup>(1)</sup>	"g" <sup>(2)</sup>	entgegen Motor counter- enginewise	wie Motor enginewise	kupplungs- abhängig clutch- dependent	motorab- hängig engine- dependent	fahrab- hängig road driven	Dauer- <sup>(3)</sup> betrieb continuous operation	Kurzzeit- betrieb intermittend operation	
12 S 2130 TD 12 S 2330 TD 12 S 2833 TD	NH/1		1000	0.81 / 1.03	-	●	-	●	-	-	●	-	
	NH/4		430	0.73 / 0.93	-	-	●	●	-	-	-	●	
	N 221/10 IT <sup>(7)</sup>	C	870 - 470	1.00 - 2.26	-	-	●	●	-	-	-	●	-
		D: NL/1	600	0.81 / 1.03	-	-	●	-	●	-	-	●	-
	D: NL/4	430	0.73 / 0.93	-	-	-	●	●	-	-	-	●	
	NH/PL		-	-	1.85	-	●	-	-	●	●	-	-
16 S 1630 TD 16 S 1930 TD 16 S 2230 TD 16 S 2330 TD	NMV 1600 L1 <sup>(4)</sup>	12 Uhr	1600	1.54	-	-	●	-	●	-	●	-	
	NMV 2000 L1 <sup>(4)</sup>	12 Uhr	2000	1.21	-	-	●	-	●	-	●	-	
	NH/1		1000	0.77 / 0.91	-	●	-	●	-	-	●	-	
	NH/4		430	0.98 / 1.17	-	-	●	●	-	-	-	●	
	N 221/10 IT <sup>(7)</sup>	C	870 - 470	0.95 - 2.00	-	-	●	●	-	-	-	●	-
		D: NL/1	600	0.77 / 0.91	-	-	●	-	●	-	-	●	-
D: NL/4	430	0.98 / 1.17	-	-	-	●	●	-	-	-	●		
NH/PL		-	-	1.85	-	●	-	-	●	●	-	-	
16 S 1830 TO 16 S 2230 TO 16 S 2530 TO 16 S 2730 TO <sup>(6)</sup>	NMV 1600 L1 <sup>(4)</sup>	12 Uhr	1600	1.54	-	-	●	-	●	-	●	-	
	NMV 2000 L1 <sup>(4)</sup>	12 Uhr	2000	1.21	-	-	●	-	●	-	●	-	
	NH/1		1000	0.91 / 1.09	-	●	-	●	-	-	●	-	
	NH/4		430	1.17 / 1.40	-	-	●	●	-	-	-	●	
	N 221/10 IT <sup>(7)</sup>	C	870 - 470	1.13 - 2.40	-	-	●	●	-	-	-	●	-
		D: NL/1	600	0.91 / 1.09	-	-	●	-	●	-	-	●	-
D: NL/4	430	1.17 / 1.40	-	-	-	●	●	-	-	-	●		
NH/PL		-	-	1.85	-	●	-	-	●	●	-	-	

# NEBENABTRIEBE / POWER TAKE-OFFS (PTO)

## MANUELLE GETRIEBE / MANUAL TRANSMISSIONS

Getriebe- Bezeichnung	Nebenab- triebtyp	Abtriebs- stelle	Abtriebsmo- ment <sup>(8)</sup> (Nm)	Drehzahlfaktor		Drehrichtung		Antrieb durch			Betriebsart		
				Speed factor		Output rotation		Driven by			Operation		
				"f" <sup>(1)</sup>	"g" <sup>(2)</sup>	entgegen Motor counter- enginewise	wie Motor enginewise	kupplungs- abhängig clutch- dependent	motorab- hängig engine- dependent	fahrab- hängig road driven	Dauer- <sup>(3)</sup> betrieb continuous operation	Kurzzeit- betrieb intermittend operation	
9 S 910 TD 9 S 1110 TD 9 S 1310 TD 9 S 1510 TD	NH/1		800	0.72	-	●	-	●	-	-	●	-	
	NH/4		430	0.92	-	-	●	●	-	-	-	●	
	N 109/10	C	410 - 630	0.88 - 1.42	-	-	●	●	-	-	-	●	-
		D: NL/1	600	0.72	-	-	●	-	●	-	-	●	-
	D: NL/4	430	0.92	-	-	-	●	●	-	-	-	●	
	N 109/PL		-	-	1.85	-	●	-	-	●	●	-	
	NMV 1600 L1 <sup>(4)</sup>	12 Uhr	1600	1.54	-	-	●	-	●	-	●	-	
	NMV 2000 L1 <sup>(4)</sup>	12 Uhr	2000	1.21	-	-	●	-	●	-	●	-	
	9 S 1110 TO 9 S 1310 TO 9 S 1510 TO	NH/1		800	0.97	-	●	-	●	-	-	●	-
		NH/4		430	1.24	-	-	●	●	-	-	-	●
N 109/10		C	410 - 630	1.19 - 1.90	-	-	●	●	-	-	-	●	-
		D: NL/1	600	0.97	-	-	●	-	●	-	-	●	-
D: NL/4		430	1.24	-	-	-	●	●	-	-	-	●	
N 109/PL			-	-	1.85	-	●	-	-	●	●	-	
6 S 700 TO 6 S 800 TO 6 S 1000 TO	NMV 1600 L1 <sup>(4)</sup>	12 Uhr	1600	1.54	-	-	●	-	●	-	●	-	
	NMV 2000 L1 <sup>(4)</sup>	12 Uhr	2000	1.21	-	-	●	-	●	-	●	-	
	NL/1 <sup>(5)</sup>		600	0.57	-	●	-	●	-	-	●	-	
	NL/4		430	0.73	-	-	●	●	-	-	-	●	
	NL/6		400	1.10	-	-	●	●	-	-	-	●	
	6 S 800 TO	NH/1 <sup>(5)</sup>		800	0.53	-	●	-	●	-	-	●	-
NH/4			430	0.67	-	-	●	●	-	-	-	●	
NH/6			400	1.01	-	-	●	●	-	-	-	●	
NH/1			1000	0.53	-	●	-	●	-	-	●	-	
6 S 1000 TO	NH/4		430	0.67	-	-	●	●	-	-	-	●	
	NL/10	C	270 - 480	1.19 - 2.03	-	-	●	●	-	-	-	●	-
		D: NL/1	600	0.53	-	-	●	-	●	-	-	●	-
		D: NL/4	430	0.67	-	-	-	●	●	-	-	-	●

- Standard
- Nicht erhältlich / Not available
- (1) = Abtriebsdrehzahl = f x Motordrehzahl / Output speed = f x engine speed
- (2) = Pumpendrehzahl = g x Abtriebsdrehzahl des Getriebes / Pump speed = g x output speed of transmission
- (3) = Für Dauerbetrieb muss grundsätzlich beim Ersteinbau eine Öltemperaturmessung durchgeführt werden. Wird die max. zul. Temperatur überschritten muss eine Zusatzkühlung eingebaut werden / Initial installation for continuous operation invariably requires measurement of the oil temperature. If the maximally permitted temperature is exceeded, an additional cooling system must be installed.
- (4) = Anschluss motor- und getriebeseitig SAE 1. Der NMV ist außerdem für weitere ZF-Getriebe mit Motoranschluss SAE 1 sowie für Getriebe anderer Hersteller geeignet. / Connection to engine and to transmission SAE 1. NMV is also suitable for other ZF transmissions with SAE 1 engine connection and for non-ZF transmissions.
- (5) = Installation nur möglich bei einem Durchmesser des Getriebeabtriebsflansches bis max. 120 mm / Installation only possible with transmission output flange diameter not exceeding 120 mm
- (6) = Für 16 S 2730 TO wird statt N 221/10.. ein N 251/10.. benötigt / For 16 S 2730 TO a N 251/10.. is required instead of N 221/10..
- (7) = Gleiche PTO-Bezeichnung für Sologetriebe und Getriebe mit Intarder / Same PTO designation for solo transmission and transmission with Intarder
- (8) = Bei Kombination von Nebenabtrieben ist Rücksprache mit ZF erforderlich / If PTOs shall be combined, consultation with ZF is required

# BEZEICHNUNG DER GETRIEBE TRANSMISSION DESIGNATIONS

	Gangzahl Number of gears	Technologiefamilie Technological family	Drehmomentgrenze Torque limit	Produktfamilie bzw. Drehmomentgrenze bei Pickup- / Van-Getrieben Product family resp. Torque limit with pickup/van transmissions	Variante Variant	Ausführung Mode	
Automatisierte Lkw-Getriebe TraXon und AS Tronic light, ASTronic mid Automated Truck Transmissions TraXon and AS Tronic light, ASTronic mid	<b>12</b>	<b>TX</b>	<b>24</b>	<b>2</b>	<b>0<sup>1)</sup></b>	<b>TD</b>	
	Zahl = Anzahl der Gänge Number = number of gears	AS = Automatisches Getriebesystem, automatic transmission system TC = TC Tronic (AS+WSK) TX = TraXon	Drehmoment [Nm] = Faktor x 100 Torque [Nm] = factor x 100	0 = AS Tronic lite 1 = AS Tronic mid kurz oder TraXon 12-Gang (kurz), AS Tronic mid short or TraXon 12-gear (short) 2 = AS Tronic mid lang oder TraXon 12-Gang (lang), AS Tronic mid long or TraXon 12-gear (long) 4 = TraXon 16-Gang, TraXon 16-gear	0 = Standard 1 = Intarder 2 = NMV 5 = kupplungsabhängiger Nebenabtrieb oder sonst. Zubehör, clutch-dependent PTO or other accessory parts	T = Truck D = Direktgang, direct drive O = Schnellgang, overdrive	Applikations-spezifische Erweiterungen möglich Application-specific upgrades possible
Manuelle Lkw-Getriebe Manual Truck Transmissions	<b>16</b>	<b>S</b>	<b>22</b>	<b>3</b>	<b>0<sup>1)</sup></b>	<b>TD</b>	
	Zahl = Anzahl der Gänge Number = number of gears	S = Synchrongetriebe, synchromesh transmission	Drehmoment [Nm] = Faktor x 100 Torque [Nm] = factor x 100	0 = Ecolite 1 = Ecomid 3 = Ecosplit	0 = Standard 1 = Intarder 2 = NMV 3 = 100 % Schub, 100 % thrust 4 = Servoshift 5 = kupplungsabhängiger Nebenabtrieb oder sonst. Zubehör, clutch-dependent PTO or other accessory parts	T = Truck D = Direktgang, direct drive O = Schnellgang, overdrive	Applikations-spezifische Erweiterungen möglich Application-specific upgrades possible
Manuelle Getriebe für Pickup und Van Manual Transmissions for Pickup and Van	<b>6</b>	<b>S</b>	<b>3</b>	<b>8</b>	<b>0</b>	<b>V</b>	
	Zahl = Anzahl der Gänge Number = number of gears	S = Synchrongetriebe, synchromesh transmission	Drehmoment [Nm] = Faktor x 100 Torque [Nm] = factor x 100	Drehmoment [Nm] = Faktor x 10 Torque [Nm] = factor x 10	0 = integrierte Kupplungsglocke, integrated bell housing 1 = separate Kupplungsglocke, separated bell housing	P = Pickup V = Van	

1) Bei Kombinationen wird die niedrigste Ziffer eingesetzt. Bei Kombinationen von Merkmalen des Sologetriebes mit solchen aus einer Erzeugniskombination (z.B. Getriebe mit Intarder) ist die Ziffer für die Erzeugniskombination vorrangig. Sind mehrere gleichrangige Merkmale kombiniert, wird die niedrigere Ziffer eingesetzt. In case of combinations, the lowest number is used. When features of a single transmission are combined with features from a combination of products (e.g., transmission with Intarder), the number for the combination of products takes precedence. If several equivalent features are combined, the lower number will be used.

**ZF Friedrichshafen AG**

Lkw- und Van-Antriebstechnik /  
Truck & Van Driveline Technology  
88038 Friedrichshafen  
Deutschland / Germany  
Telefon / Phone +49 7541 77-0  
[www.zf.com/lkw](http://www.zf.com/lkw)  
[www.zf.com/trucks](http://www.zf.com/trucks)



**MOTION AND MOBILITY**